

**D****3500 SERIES CONVECTION STEAMER  
ON 36" WIDE DIRECT STEAM BASE**

JOB NAME: \_\_\_\_\_

ITEM NO.: \_\_\_\_\_

NO. REQUIRED: \_\_\_\_\_

**FOOD SERVICE EQUIPMENT**  
Direct Steam Steamer**MODELS**

- 3500M36D - 6 pan steamer on 36" direct steam base

**DESCRIPTION**

Market Forge Model 3500M36D direct connect convection steam cooker. Will be integrally mounted on a cabinet base containing direct steam connections.

The 3500 will be of double-wall construction with 1" (25mm) thick insulation between cooking compartments and exterior walls, and will have two 18 gauge stainless steel welded cooking compartments with coved internal corners, and a 16 gauge stainless steel front panel.

Each cooking compartment on the 3500 has a positive slam action, field-reversible door constructed of Type 304 stainless steel. Door latches are spring loaded. The inner door gasket is a one-piece NSF-approved silicone rubber gasket. The cooking compartment is equipped with a door interlock (switch) that shuts off steam to the cooking compartment when the door is opened. Factory installs units with door opening from the right, see diagram.

Each compartment will be equipped with a perforated steam inlet baffle positioned for precise application of high velocity steam across the surface of food. Controls for each compartment will include a 60-minute load compensating timer with constant steam position, an indicator light, steam inlet solenoid valve, pressure relief valve, vacuum breaker, and an automatic cold water steam condenser system, and a removable drip trough.

Each compartment will be independently and automatically controlled by setting the cooking time on the 60-minute timer. At the end of cooking time, indicator light will turn off and a continuous signal will sound. Signal is silenced by returning the timer to the OFF position.

Stainless steel cabinet base will match other Market Forge stainless steel equipment. A stainless steel frame will be equipped with 6" (152mm) stainless steel legs and adjustable bullet feet, reinforced stainless steel counter-top, and stainless steel lift-off front cover. A cold water condenser will automatically condense all exhausted steam into water before it is released from the cooker.

**OPERATION WILL BE BY:**

Direct steam at a minimum of 15 PSI (1 kg/cm<sup>2</sup>). Unit will be equipped with ball float trap to remove condensate from incoming steam line and a 3/4" (19mm) NPT pressure reducing valve which will reduce initial pressure of 20 to 50 PSI (1.3 to 3.5 kg/cm<sup>2</sup>) to required 15 PSI (1 kg/cm<sup>2</sup>) operating pressure. Minimum BHP required: 3.0 BHP.

**CAPACITY**

Each compartment will accommodate the following:

- (6) 12" x 20" x 1" deep pans
- (3) 12" x 20" x 2 1/2" deep pans
- (2) 12" x 20" x 4" deep pans

**SHIPPING WEIGHT**

- 380 lbs (172 kg)

**OPTIONS & ACCESSORIES**

(at additional charge)

- **Pans & Covers**

- 12" x 20" pan cover
- 12" x 20" x 1" solid pan
- 12" x 20" x 1" perforated pan
- 12" x 20" x 2-1/2" solid pan
- 12" x 20" x 2-1/2" perforated pan
- 12" x 20" x 4" solid pan
- 12" x 20" x 4" perforated pan
- 12" x 20" x 6" solid pan
- 12" x 20" x 6" perforated pan
- Digital Countdown Timer
- Prison package, includes lockable stainless steel hinged control cover, tamper proof screws, (4) 6" adjustable flanged feet
- 60" water hose with quick disconnect
- 6" adjustable flanged feet
- Condensate Return Kit



**MARKET FORGE**  
INDUSTRIES INC.



**D****3500 SERIES CONVECTION STEAMER  
ON 36" WIDE DIRECT STEAM BASE**

DETAILS &amp; DIMENSIONS

**SERVICE CONNECTIONS**

<b>EC</b>	<b>Electrical Connection</b> - 120 Volts AC, 60 Hz, single phase, and a 9 foot Power Cord/NEMA 5-15.
<b>CW</b>	<b>Cold Water</b> - 3/8" (10mm) NPT for cold water to condenser. Cold water lines will have a maximum of 50 PSI (3.5kg/cw2) and a minimum of 25 PSI (1.8 kg/cw2) water pressure.
<b>CR</b>	<b>Condensate Return</b> - 1/2" (13mm) N.P.T. female from ball float trap may be connected to condensate return line (optional at extra cost).
<b>D</b>	<b>Drain</b> - Pipe full 2" (50mm) NPT to flush floor drain capable of receiving water flowing at a maximum rate of 5 gallons (19 liters) per minute. <b>DO NOT MAKE SOLID CONNECTION TO FLOOR DRAIN.</b>
<b>S</b>	<b>Steam Supply</b> - Minimum BHP required: 3.0 BHP at a minimum pressure of 15 PSI (1.0 kg/cm2). 3/4" (19mm) NPT pressure reducing valve will reduce incoming pressure of 20 to 50 PSI (1.3 to 3.5 kg/cm2) to required 15 PSI (1.0 kg/cm2).

DIMENSIONS ARE IN INCHES [MM]

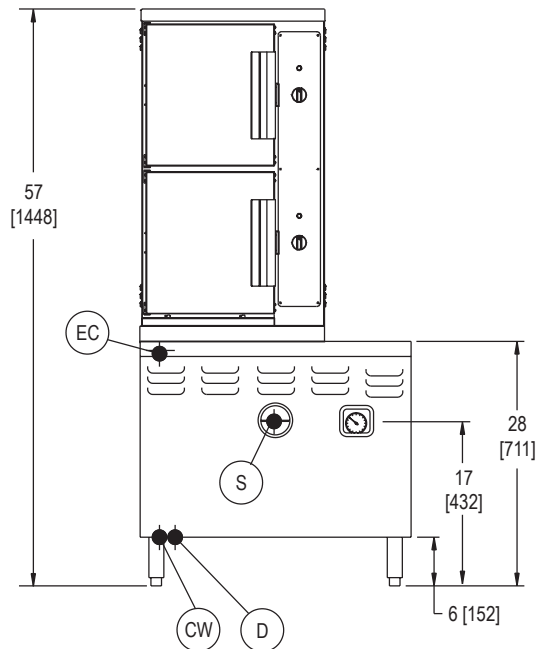
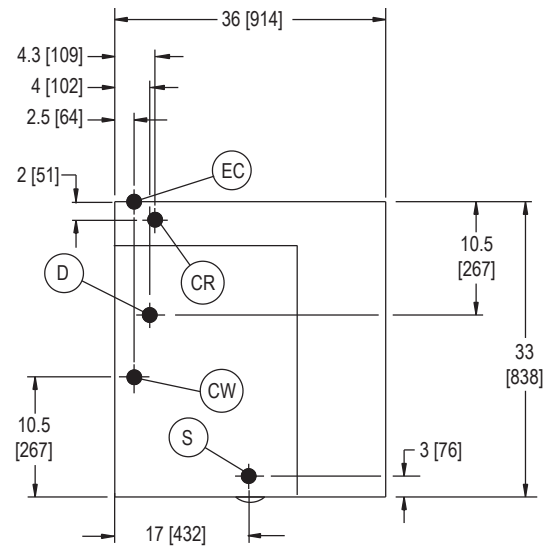

**NOTES:** The only available space to supply utilities is the 6" (152mm) height between the floor and the cabinet.

PVC & CPVC are not acceptable materials for drain lines.

The drain piping must consist of temperature resistant material, greater than 160°F, and be of adequate diameter not to cause flow restriction. Improper materials may deform and cause restrictions, thus affecting performance.

**WATER SUPPLY**

Good quality water feed is the responsibility of the owner. Water quality must be within the following general guidelines.

TDS: 40-125 ppm	Chlorides: <25 ppm
Silica: <13 ppm	pH: 7.0 - 8.5
Chloramine: <0.2 ppm	Chlorine: <0.2 ppm
Hardness: 35-100 ppm	

The best defense against poor water quality is a water treatment system designed to meet your water quality conditions.

Appliance to be installed with backflow protection according to federal, state or local codes.

The manufacturer reserves the right to modify materials and specifications without notice.

**FOOD SERVICE EQUIPMENT**  
Direct Steam Steamer